

Savannah

Square Columns

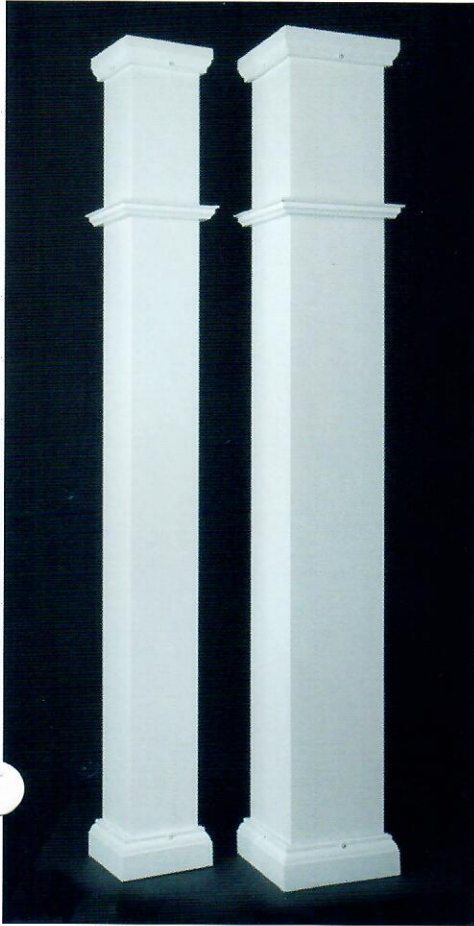

The **Savannah** square columns are completely maintenance free.

Made of heavy gauge aluminum for even greater support.

The **Savannah** columns can be painted in any desired color.

Vinyl acrylic paint is recommended.

Columns can also be pre-painted at the factory with a 30% up-charge.

Easy to assemble and install.

See instructions below.

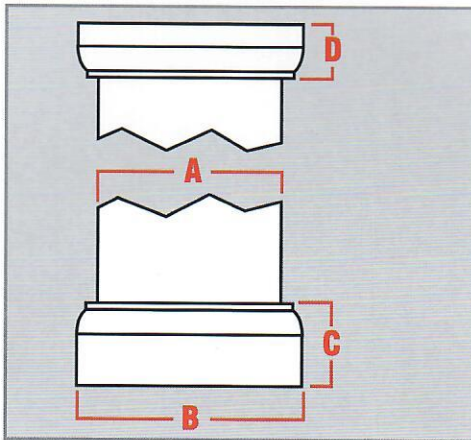

SAVANNAH SQUARE COLUMNS

Col. size	Standard Length	Approx. weight load*
6"	8' 9' 10' 12'	20,500
8"	8' 9' 10' 12' 16' 18'	26,500

* Maximum Load – No Safety Factor Included
Available in White only

SIZE	ACT. SIZE	CAP & BASE SIZE			
		A	B	C	D
6"	5 1/2"	7 3/8"	2 3/4"	2"	
8"	7 1/2"	9 3/8"	2 3/4"	2"	



ASSEMBLY and INSTALLATION



1 Measure the required length. Using a hack saw, cut the column slightly longer for a tight fit.

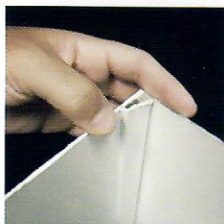

2 Fit the four sections together – tongue into groove. It is best to put two quarter sections together. Repeat with other two sections then join the two half sections together – tongue into groove – and tap with heel of the hand until sections snap and lock together.

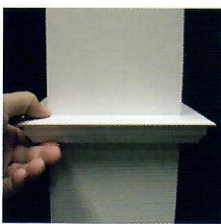

3 Slide astragal ring over assembled column. Position at height desired (usually about 12 to 18 inches below the cap). Drill 1/8 inch hole through flat surface of astragal ring and into the column. Secure with 1 1/4 inch screws on at least two sides.



4 Slide cap and base onto each end of the column. The column must extend through the cap and base for proper installation.

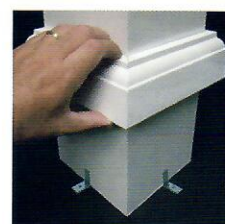

5 Secure columns in place (optional). Locate L-shaped brackets around column top and bottom. Drill holes and secure in place to upper and lower structure.

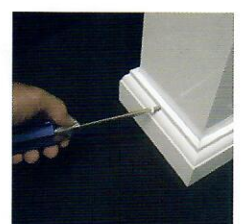

6 Secure caps in place. Drill two holes opposite each other, through caps and into column. Secure caps in place with screws.

STYLE-RITE Industries

Manufacturers of Aluminum Products

P. O. Box 336 • Penn, PA 15675
1-800-789-5374

Phone 724-527-2866 Fax 724-527-3906